

PHONAK

hearing systems

MicroLink / MicroVox
User Guide

CE 0681 !

We would like to introduce to you something unique: Phonak's FM systems.

These systems are based on technology which effectively overcomes three fundamental problems faced by hearing-impaired people: ambient noise, distance and reverberation.

MicroLink and MicroVox are Swiss quality products from Phonak, a company whose name stands for uncompromising reliability and cutting-edge innovation in the service of people everywhere. If used properly, your FM system will give you many years of exceptional service.

Important:

This product may only be used in countries in which the preset frequency has been approved. Please read the instructions before operating the product. Also, contact your hearing care professional to verify frequency approvals before you travel to a foreign country.

Yours

Phonak AG

Contents

	Page
How your FM system works	2
Transmitter	
<input type="checkbox"/> HandyMic	3
<input type="checkbox"/> TX2	17
Receiver	
<input type="checkbox"/> MicroLink MLx	24
<input type="checkbox"/> MicroLink ML3S, ML4S, ML5S, ML6, ML7	28
<input type="checkbox"/> RX2 receiver PFM-1 / COM-1	35
Operating range	43
Care and maintenance	44
Important notes	49
Warranty	50

How your FM system works

An FM system consists of two basic components:

- ① A transmitter with an integrated microphone for the person speaking.
- ② A receiver fitted to the hearing instrument of the person listening.

The desired signal – for example, a speaker's voice or the sound from a TV – is picked up by the microphone which is placed near to the source of the sound. The transmitter sends an FM signal to the receiver, which immediately relays this to the hearing instrument for you to hear – crystal clear!



Transmitter HandyMic

The HandyMic, which transmits cable free, can be used in three different ways:

The interview technique

This is ideal when you are listening to more than one person. Just point the HandyMic at the speaker! If the Zoom or SuperZoom function has been activated, then this technique effectively suppresses a noisy background.

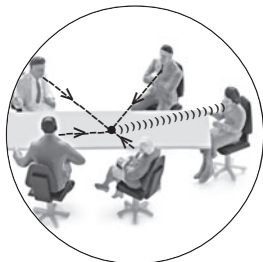

In quiet surroundings, on the other hand, set the microphone to wide-angle mode and place it in the middle of the group of people (on the table, for example).

When using the interview technique, the use of an external antenna is generally not necessary.

The companion technique

This method is recommended when you are conversing with or listening to a single person. Your partner places the HandyMic* – in Zoom mode – in his or her breast pocket, or wears it on a cord around their neck.

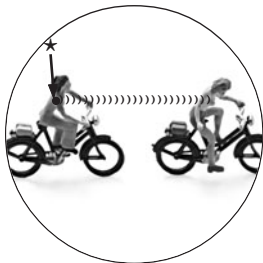

The external antenna should always be connected to the HandyMic when your partner is wearing it.

The direct-input technique

Using the audio cable supplied with the system, the HandyMic can be connected directly to any sound system, including a TV, radio, walkman, movie projector, amplifier, cassette-player etc.

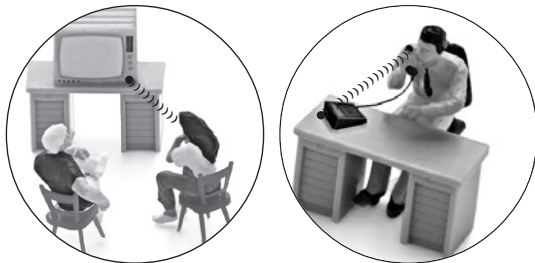

This allows you to hear the sound directly from the source without having to adjust the volume (of the TV, for example). With some TVs, using an audio cable switches off the internal loudspeakers, but your TV dealer will be able to make the small modification necessary to override the internal switch.

You may even connect the system directly to your telephone, if it has an audio output socket. Alternatively, use the optional adapter available for your HandyMic. Switching off the microphone then allows you to hear the telephone signal without any background noise.

To use the audio cable, switch of the slide switch (see page 9) and plug in the audio cable into the multifunction socket. The HandyMic switches on automatically as soon as a signal is detected. We recommend to use the mains plug-in charger unit with the HandyMic, when you are listening to the radio or TV.

The plug on the audio cable supplied with the HandyMic fits the standard audio output socket used in most sound systems. If your system has a socket of another size, use the adapter plug supplied. If this does not fit, please ask your electronic equipment dealer for a suitable connector.

When the HandyMic is plugged into external audio equipment, the cable also serves as the antenna.

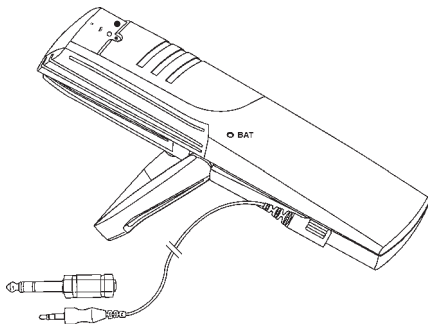

Description

- ① Slide switch symbols:
 - = Off
 - = Wide-angle microphone
 - ☰ = Zoom microphone
 - ☶ = SuperZoom microphone
- ② External power socket
- ③ Slide switch
- ④ Low battery / charging indicator
 - a. When the red light blinks, the battery needs recharging
 - b. During recharge the red light illuminates continuously
- ⑤ Multifunction socket. This allows the HandyMic to be connected to audio equipment (e.g. TV, radio etc.). The external aerial can be plugged in here to extend the operating range of the system.
- ⑥ Stand
- ⑦ Microphone ports
- ⑧ Plug-in frequency module

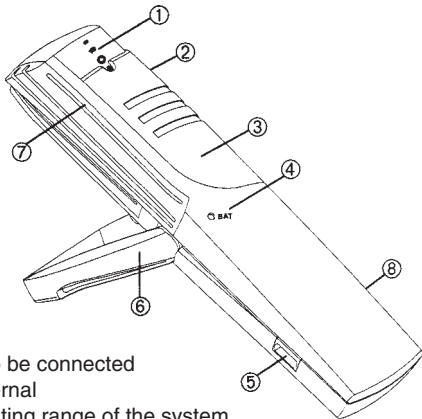

Basic parts

The following parts are supplied with your HandyMic:

A

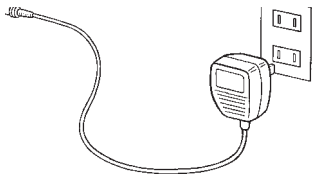

B



C

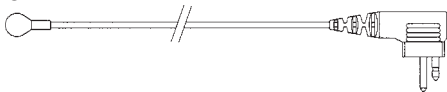

D

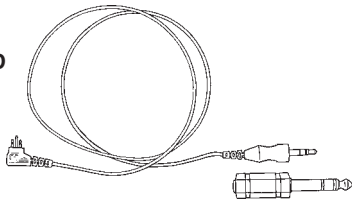

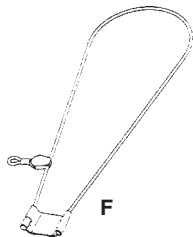
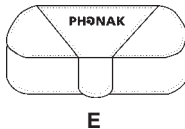

A. Mains plug-in charger unit

B. Frequency module

The frequency module is already installed when you receive your HandyMic. The number of the transmitter and MicroLink receiver must be the same for these units to function together correctly.

C. External antenna for the HandyMic

D. Audio cable for connecting TV, radio etc. to the HandyMic

E. Case

F. Necklace cord and adapter plate (optional)

Frequency Module

The replaceable plug-in frequency modules are numbered and color-coded. They provide a simple and convenient way of changing the operating frequency. To work correctly, however, the number and color of the module must be the same as the MicroVox and MicroLink receiver.

The frequency module is already installed when you receive your HandyMic. If you need to change the operating frequency or channel, proceed as follows:

Exchanging the Frequency Module

- ① Press firmly on the cover of the compartment holding the frequency module and slide it in the direction of the arrow.
- ② Flip up the holder as shown.
- ③ Pull out the frequency module.
- ④ Insert a new module.
- ⑤ Close the holder.
- ⑥ Slide it back into place.

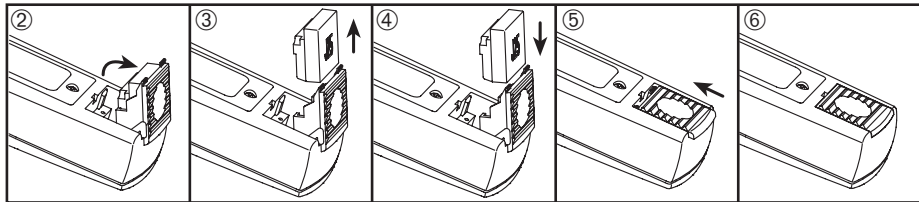
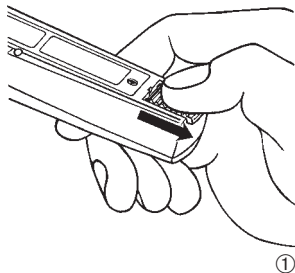

Connecting the Charger

The HandyMic uses a rechargeable NiMH (nickel metal-hydride) battery, which can be recharged up to 1000 times. A fully charged battery can be used for about 13 hours. Recharge the battery daily.

Always carry out a 12-hour charging cycle if in doubt about the battery's charge condition. The battery cannot be overcharged even if it is connected to the charger for an extended period.

- ① Plug the power supply into a mains power socket.
- ② Plug the cable into the external power socket on the HandyMic.

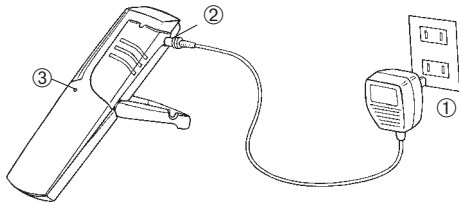

- ③ The red low battery / charging indicator now lights up continuously. The time taken to fully recharge the battery depends on its charge condition. (The red indicator light remains illuminated so long as the charger unit is in use, even when the battery is fully charged).

Connecting the external antenna

Use the external antenna whenever the distance between yourself and the HandyMic is more than two meters (about six feet).

The cable may be oriented upwards or downwards. It should be kept free of knots at all times.

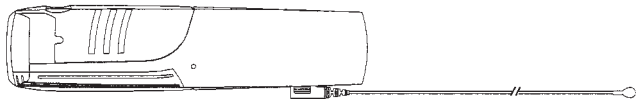
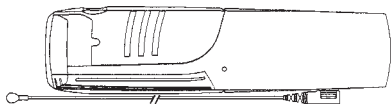

TX2

Description

- ① Microphone socket
- ② On/Off switch
- ③ Audio input socket for connecting TX2 directly to external audio equipment (e.g. TV, radio, tape recorder etc.)
- ④ Color code for channel identification
- ⑤ Number code for exact channel identification
- ⑥ Battery compartment
- ⑦ Low battery warning light
- ⑧ Clip with name and address label

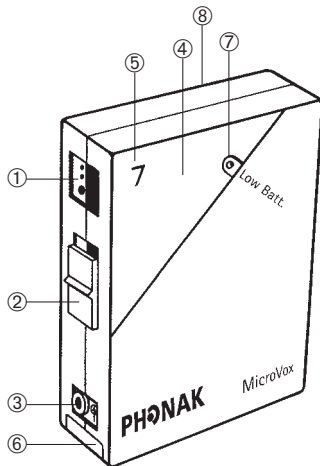

Basic parts

The following items are supplied with your TX2:

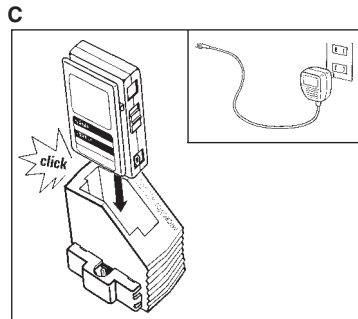
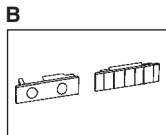
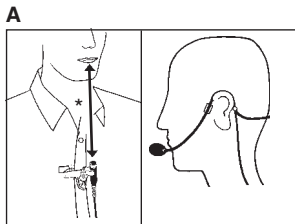

- A. Lapel microphone with alligator clip
(*mouth-to-microphone distance 15–20 cm)
or head-set microphone
- B. Battery cover
- C. Charger and power supply unit (optional)

Connecting the microphone

Insert the microphone cable plug into the socket on the TX2 unit. Use only an original Phonak microphone.

Important: The microphone cable also serves as the antenna and should be kept free of knots at all times.

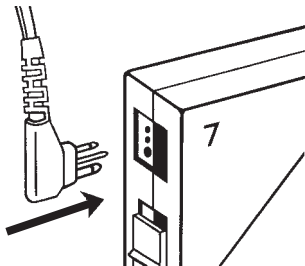

Batteries

You may use disposable alkaline batteries, or NiCd (nickel cadmium) or NiMH (nickel metal-hydride) type rechargeable cells. After you have decided which type of batteries to use, you must insert the appropriate battery compartment plate, as shown in the drawing. Thanks to its exceptionally low current consumption, the TX2 requires only a single type AA battery. When changing the battery follow the directions on polarity given in the battery compartment.

Note: Please dispose of used batteries in an environmentally friendly way!

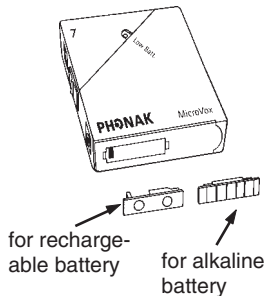

Warning: Never keep batteries where small children or pets may reach them. If a battery is swallowed, contact a doctor immediately!

Inserting the battery

1. To open the battery compartment slide the cover in the direction of the arrow.
2. Remove the old battery then insert a new one, observing the polarity indicated by the markings on the compartment.

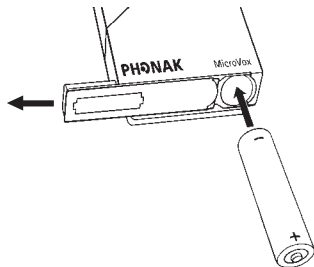

Note: When using the battery compartment cover for rechargeable cells, note that this cover locks into place and must be removed with a screwdriver.

Switching on the TX2 transmitter

To turn on the device slide the ON/OFF switch down so that the red marking is completely uncovered. If the low battery indicator lights up, you must first replace or recharge the battery.

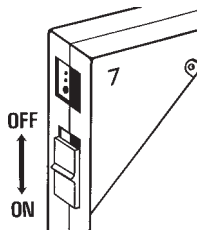

Recharging the TX2

The charger unit is very simple to use – simply plug the end of the power cable into the charger then plug the charger into a mains power socket.

Note: Use only the power cable supplied.

Now insert the transmitter into the charger until you hear a click. During the recharging process the TX2 is automatically switched off. A red light on the charger indicates that charging is taking place. (This light remains on when the battery is fully charged.) After charging is completed, remove the transmitter by pressing gently on the clip and withdrawing it from the charger.

Note: The charger is designed to prevent batteries from being overcharged.

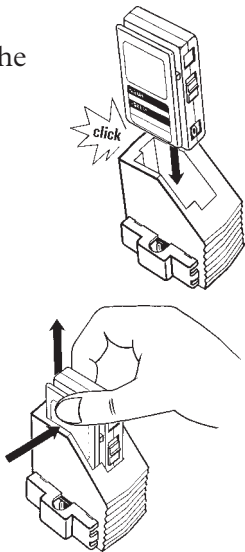

Receiver

MicroLink MLx

MicroLink MLx can be used with Behind-The-Ear (BTE) hearing instruments from several different manufacturers.

Note: We recommend that you only use MicroLink MLx with hearing instruments which have been tested and recommended by Phonak for this purpose. For more detailed information please consult your hearing care professional.

Two versions of MicroLink MLx

MicroLink MLx is available in two versions which are differentiated by the position of the plugs. The correct version for your needs is defined by the appropriate Audio-shoe.



MLx with plugs oriented lengthways



MLx with plugs oriented transversely

Important: Place the hearing instrument with audio-shoe and MicroLink MLx in front of you as shown in the sketch. The green dots must be visible at the top and bottom of the MicroLink MLx unit. If this is not the case please contact your hearing care professional.

Correct MLx version fitted to hearing instrument

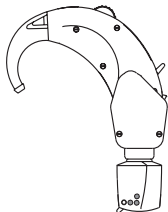

Wrong MLx version fitted to hearing instrument

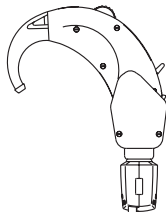

Description of the instrument

- ① Audio-shoe
- ② Frequency identification code
- ③ Euro-plug socket
- ④ MicroLink MLx receiver
- ⑤ Plug
- ⑥ Switch

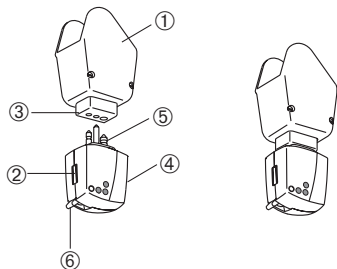

Note: There is no need to separate the MicroLink MLx from the Audio-shoe.

Attaching and removing the MicroLink MLx

1. Check that the MicroLink MLx is correctly inserted in the Audio-shoe (see illustration).
2. Now, with the Audio-shoe and MicroLink MLx connected, attach to or remove from the hearing instrument as one unit. (See page 30.)



Switch positions

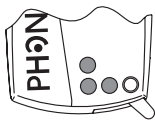

○ = OFF

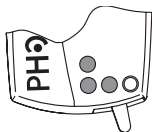

● = *)

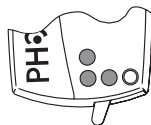

●● = *)

- *) The position of the switch depends on the hearing instrument type. Please ask your hearing care professional in which position your MLx should be set.

MicroLink ML3S, ML4S, ML5S, ML6, ML7

Description of the MicroLink models

- ① Audio-shoe
- ② Frequency identification code
Number and color codes for exact frequency channel identification. To ensure proper reception, check that the channel and transmitter numbers are identical.
- ③ MicroLink receiver
FM receiver with integrated antenna
- ④ Socket for optional external antenna (available for ML3S/ML4S/ML5S and ML6). The threaded socket accepts a screw-in antenna to extend the MicroLink reception range.
- ⑤ Mute switch to reduce the sensitivity of the hearing instrument microphone by 20 dB, so enhancing the effect of the FM system (only applies to ML3S/ML4S and ML5S). With the ML6, the mute function is activated via the remote control.
- ⑥ Frequency module with integrated antenna. This module is locked in place.
For special applications the frequency module may be replaced. Your hearing care professional will explain in detail this special feature.
- ⑦ Release button

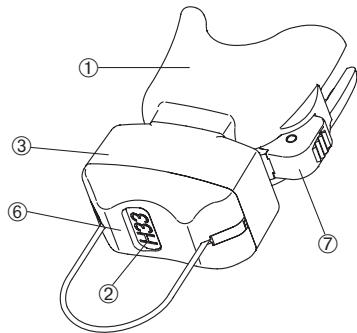
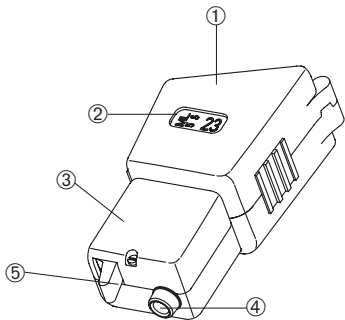
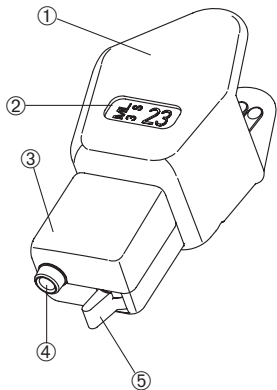

Attaching and removing the MicroLink receiver

ML3S, ML4S, ML5S or ML6

- ① Slip the MicroLink receiver over the lower section of the hearing instrument. You will hear a click when the two parts are correctly engaged. The MicroLink receiver is activated when you set the switch on the hearing instrument to the correct audio input setting. Please consult your hearing care professional on this point.

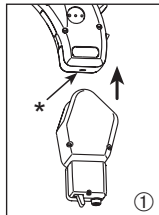

ML3S/ML4S

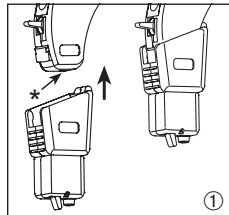

ML5S/ML6

*Note: the underside of the battery compartment must be slotted, otherwise the MicroLink may be damaged.

- ② To remove the MicroLink receiver, twist off as illustrated. The MicroLink receiver is now switched off. The minimal power required by the receiver is drawn from the hearing instrument battery. To maximize the operating lifetime of the battery, we recommend that you always remove the MicroLink receiver(s) from your hearing instrument(s) when not in use.

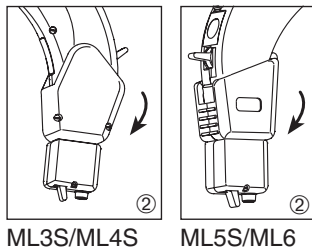

- ③ The attenuating or mute switch reduces the sensitivity of the hearing instrument microphone by 20 dB. This suppresses unwanted background noise, and enhances the MicroLink signal.

Switch position FM + M setting: The signal from the transmitter via MicroLink and the signal from the hearing instrument microphones are equally loud.

***Switch position FM setting:** The hearing instrument microphone is attenuated by 20 dB, so that the MicroLink signal is louder.

④ An optional external antenna can be used to extend the range of the system. Use this **only** to increase the reception distance or to improve the quality of the transmission. Screw the antenna carefully into place, until light resistance is felt. Do not over-tighten.

*) The position of the switch depends on the hearing instrument type. Please ask your hearing care professional in which position your MLx 32 should be set.

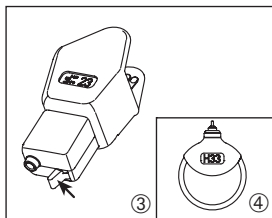

ML3S/ML4S

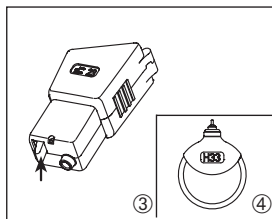

ML5S/ML6

MicroLink ML7

- ① Slip the MicroLink receiver over the lower part of the hearing instrument until it clicks into place. Check that it is correctly attached by pulling the MicroLink gently downwards.
- ② To remove the MicroLink grasp it firmly as shown and press the release button.
- ③ Pull the MicroLink downward.

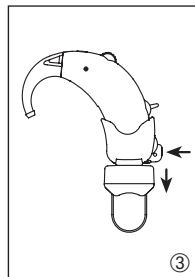
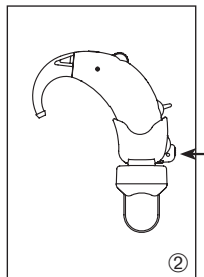
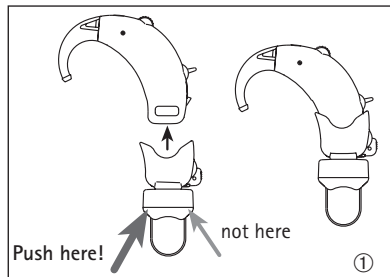

MicroLink locking mechanism (only ML7)

An optional locking mechanism allows you to lock the MicroLink and hearing instrument together, preventing accidental loss.

- ① To remove the MicroLink when locked, insert the tip of a small screwdriver into the slot in the cover, as shown in the drawing.
- ② Rotate the screwdriver firmly but carefully towards the hearing instrument as shown to release the MicroLink.

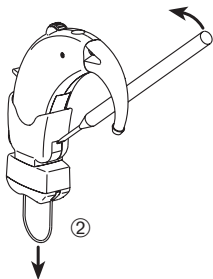
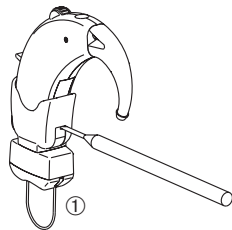

RX2 receiver PFM-1/COM-1

Description

- ① Output socket
- ② Hearing instrument connecting cable with integrated aerial
- ③ Plug-in, color-coded frequency module
- ④ Number code for exact channel identification
- ⑤ Battery compartment
- ⑥ Low battery indicator light
- ⑦ No transmission warning indicator
- ⑧ On/Off switch
- ⑨ Clip with name and address label
- ⑩ Volume control
- ⑪ PFM-1: frequency correction switch (D/N)
COM-1: output impedance switch (L/N)
- ⑫ Hearing instrument microphone attenuating switch (only available on PFM receivers)

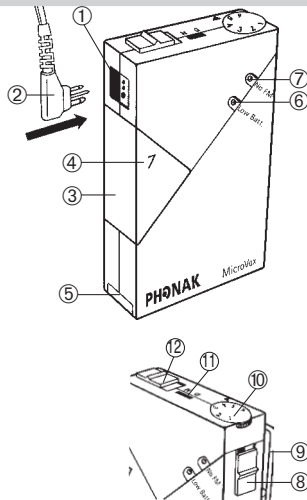

Changing batteries

To change the batteries of the RX2, follow the instructions given in the “Batteries” section of the chapter “TX2” in this handbook.

Connecting hearing instruments

Insert the right-angled plug on the connecting cable into the socket on the receiver. Be careful to observe the polarity of the plug contacts.

The cable can only be connected to the hearing instruments when the latter are fitted with appropriate audio-shoes.

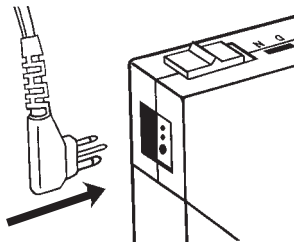

MicroVox receiver type COM: Connect the induction loop or the stereo headphones to the receiver. When using an induction loop, switch the hearing instruments to “T” or “MT”.

Frequency correction for directional microphones (PFM-1 only)

The directional microphones used in hearing instruments have a slightly different frequency response than omnidirectional types. Using the D/N switch allows you to correct this by modifying the frequency response to maintain consistency of tone. Therefore when using the RX2 with a hearing instrument fitted with a directional microphone, set this switch to position “D”.

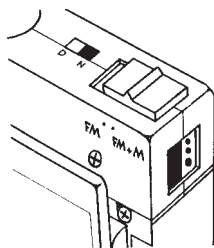

Position N: Omnidirectional

Position D: Directional

RX2 type COM-1: The L/N switch must always be on position “N”.

Switching on the RX2

To switch the instrument on, slide the On/Off switch downward until the red mark is fully exposed.

If the low battery indicator blinks after the device is switched on, then the batteries either need recharging (use a MicroVox charger) or replacing, depending on which kind are fitted. See the “Batteries” section of the TX2 chapter.

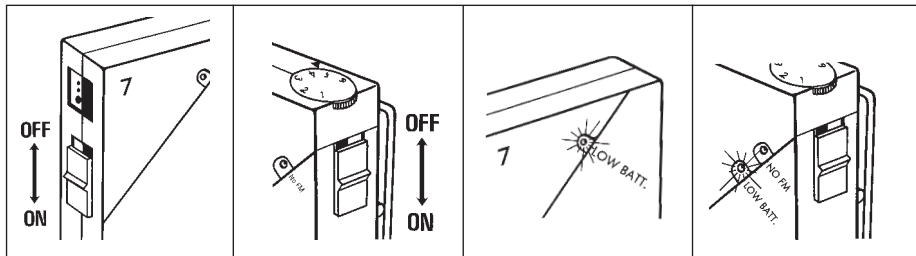

Volume control

The volume control on the RX2 receiver only matches the signal level to that of the hearing instrument. The actual volume adjustment should always be made at the hearing instrument.

The control should be set so that signals from the hearing instrument microphone and the FM-system microphone are equally loud. Your hearing care professional will be glad to help in adjusting the volume to the correct level.

Adjusting the volume control

PFM-1

Set the RX2 to the “FM + M” position. Adjust the volume of the hearing instruments, then set the RX2 to the “FM” position. The volume control wheel can now be fixed in place with the locking screw on the back of the instrument.

Caution: Do not overtighten.

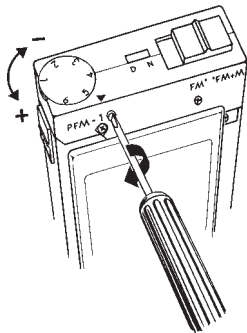

COM-1

Set your hearing instruments to position “M” and adjust the volumes. Then set the hearing instruments to position “T” and adjust the volume control on the RX2 so that the volume is the same as that of the hearing instruments.

Hearing instrument microphone attenuation (PFM-1 only)

This switch* reduces the hearing instrument microphone signal by 20 dB (with digitally programmable hearing instruments with a DHC).

“FM+M” position: Both microphones are equally loud.

“FM” position: Hearing instrument microphone attenuated.

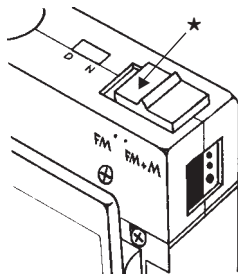

Changing frequency modules

The transmission frequency channel can be changed by replacing the plug-in frequency module. The color of the module and the number printed on it indicate the channel code. To remove the module pull it forward away from the MicroVox device.

Important: The color of the frequency module and the number printed on it must be the same as those of the transmitter unit.

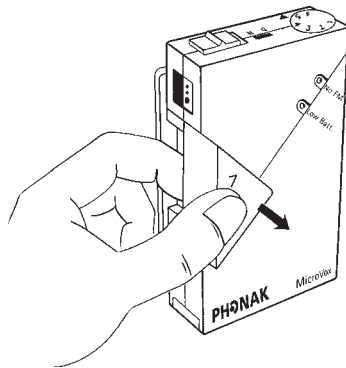

Operating range

Phonak FM systems have an operational range of 7 to 15 meters. This allows users normal communication in their educational, professional and private lives at all times.

The range depends on the condition of the batteries in the transmitter and hearing instrument, as well as local interference and radio transmission conditions which may be affected by building design, metal walls, doorways etc.

Care and maintenance

Daily check

Perform a daily “listening check” to monitor the performance of your hearing instrument.

1. Remove any dirt or foreign matter from the MicroLink, the hearing instrument or the ear-piece with a paper handkerchief.
2. Listen to the hearing instrument by itself.
3. Listen to the hearing instrument with the MicroLink, on the “M + FM” setting.
4. Listen to the system on the “FM” setting with the transmitter on.
5. Listen to the system on the “M + FM” setting with the transmitter on.

Batteries

1. Maintain a schedule of battery usage and change the battery consistently on the selected day. **Change the battery before it is fully discharged as the performance of your hearing instrument will be affected by a low battery.**
2. If you use **rechargeable batteries** with your transmitter, recharge them daily. If you do not use the transmitter for more than five days, remove the plug-in charger unit from the mains outlet. You can keep the transmitter in the charger unit when it is not in use.

Routine maintenance

Ask your hearing care professional every six months to check that your MicroLink system is working correctly.

Troubleshooting

You can cure most problems which arise with an FM system by yourself, at home. Work through the following list:

1. Carry out the daily check, as described previously, to identify any possible problems.
2. The most frequent problems encountered with an FM system are either a distorted signal, or no sound whatsoever. Proceed as follows:

- Check the hearing instrument battery with a battery tester.
 - Check the transmitter battery with a battery tester.
 - Check that all the switches are set to the correct positions for normal operation.
 - Check that the microphone cable is correctly connected to the transmitter.
3. Check that the earmold and hearing instrument are correctly connected, and that the earmold tubing is not blocked.

4. If you use a battery charger with the transmitter:
Ensure that it is correctly plugged into a mains outlet, and that the transmitter is correctly located in the charger. The red LED should light up to indicate that the charging process is functioning correctly. A recharge generally takes 10–12 hours.

5. If your unit still does not work after all the tests above have been made, please consult hearing care professional for more help.

Important notes

1. The unit may only be opened by an authorized agent.
2. Do not use water or electronic cleaning methods on your hearing instrument.
3. Do not attempt to recharge the hearing instrument battery.
4. You cannot use two transmitters on the same frequency in close proximity.
5. Do not store the system where it may come into contact with hairspray.
6. Only use original Phonak accessories.
7. Do not connect your MicroLink receiver to another person's hearing instruments.
8. Do not use your MicroLink system in locations where it is forbidden to use electronic devices.
9. Before using the system in another country, contact your hearing care professional to make sure your channel is permitted in that country.



The symbol with the crossed out disposal bin indicates that this hearing instrument shall not be treated as household waste. Please hand over your old or unused hearing instrument to the applicable collection point for the recycling of electrical and electronic equipment or bring your old hearing instrument to your hearing care professional for appropriate disposal. By ensuring this product is disposed of correctly, you will help prevent potential negative effects on the environment and human health.

Service and Warranty

Phonak offers you a comprehensive global warranty which becomes effective on the date of purchase. Please ask your hearing care professional about the details and duration. This warranty covers any repairs due to defects in material and/or workmanship. The warranty does not cover damage from improper handling or care, exposure to chemicals, immersion in water or undue stress. Damage caused by third parties or non-authorized service centers renders the Phonak warranty null and void. This warranty does not include any services performed by a hearing professional in their office. This warranty applies to the Phonak products listed below:

Serial number FM receiver right:

Serial number FM receiver left:

Date of purchase:

Serial number transmitter:

MicroVox T**FCC ID: KWC001T**

This device complies with part 15
of the FCC rules

Made in Switzerland

ML/MV Transmitter**FCC ID: KWC004T**

This device complies with part 15
of the FCC rules

Made in Switzerland

MicroVox Receiver**FCC ID: KWC002R**

This device complies with part 15
of the FCC rules

Made in Switzerland

MicroLink Receiver**FCC ID: KWC005R**

This device complies with part 90
of the FCC rules

Made in Switzerland

MicroVox R**FCC ID: KWC001R**

This device complies with part 15
of the FCC rules

Made in Switzerland

ML/MV Transmitter**FCC ID: KWC002T**

This device complies with part 15
of the FCC rules

Made in Switzerland

MicroLink Receiver**FCC ID: KWC003R**

This device complies with part 90
of the FCC rules

Made in Switzerland

Declaration of conformity

Phonak AG, Laubisrütistrasse 28, 8712 Stäfa, Switzerland

Confirms that the HandyMic and MicroVox TX2 correspond to the standards EN 300-422, EN 300-445 and EN 60065 including all necessary annexes.

The HandyMic and MicroVox TX2 are used by hearing impaired people. To operate the HandyMic and MicroVox TX2, hearing instruments with FM receivers (e.g., MicroLink) are required. The user benefit of FM is an improved signal-to-noise ratio which leads to an optimized speech understanding even in very difficult listening situations.

Phonak AG

Stäfa, Switzerland

Date: 26th March 2002



Phonak distributors worldwide

Group companies:	(detailed information on www.phonak.com)
Australia	Phonak Australasia Pty. Ltd., Baulkham Hills N. S. W. 2153
Austria	Hansaton Akustische Geräte GmbH, 5020 Salzburg
Belgium	Lapperre N.V., 1702 Groot-Bijgaarden
Brazil	CAS Produtos Médicos, São Paulo – SP 04363-100
Canada	Phonak Canada Limited, Mississauga, Ontario L5S 1V9
China	Phonak Group (China), Shanghai City 200233
Denmark	Phonak Danmark A/S, Nitivej 10, 2000 Frederiksberg
France	Phonak France SA, 69500 Bron
Germany	Phonak GmbH, 70736 Fellbach-Oeffingen
Italy	Phonak Italia S.r.l., 20159 Milano
Japan	Phonak Japan Co., Ltd., Tokyo 101-0044
Jordan	Phonak Middle East, 11181 Amman
Netherlands	Phonak B.V., 3439 ME Nieuwegein
New Zealand	Phonak New Zealand Ltd., Takapuna, Auckland 9
Norway	Phonak AS, 0105 Oslo
Poland	Phonak Polska Sp. z o.o., 00-567 Warszawa
Spain	Phonak Ibérica S.A., 03008 Alicante
Sweden	Phonak AB, 117 34 Stockholm
Switzerland	Phonak AG, Phonak Schweiz, 8712 Stäfa
United Kingdom	Phonak UK Limited, Warrington, Cheshire WA1 1PP
USA	Phonak LLC, Warrenville, IL 60555-3927
Independent general agents:	A complete list of Phonak distributors is available at Phonak's Internet site: www.phonak.com . Please visit us or ask your hearing care professional for information.
Manufacturer:	Phonak AG, Laubisrütistrasse 28, CH-8712 Stäfa, Switzerland



Your hearing care professional: